

## 11. ELECTRIC CURRENT

### Questions and Answers

#### 1. Explain how electron flow causes electric current with Lorentz-Drude theory of electrons?

**A.** Drude and Lorentz, proposed that conductors like metals contain a large number of free electrons while the positive ions are fixed in their locations. The arrangement of the positive ions is called lattice.

When the ends of the conductor are connected to the battery through a bulb, the bulb glows because energy transfer takes place from battery to the bulb. The electrons are responsible for this transfer of energy. If the electrons are responsible for transfer of energy from battery to bulb, they must have an ordered motion. When the electrons are in ordered motion, there will be a net charge crossing through any cross section of the conductor. This ordered motion of electrons is called electric current.

#### 2. How does a battery work ? Explain.

**A.** When a conducting wire is connected to the terminals of the battery, a potential difference is created between the ends of the conductor. This potential difference sets up an electric field throughout the conductor. We know that the conductor contains large number of electrons. The electrons near the positive terminal of the battery are attracted by it and start to move towards positive terminal. As a result, the amount of positive charge on this plate decreases. So the electric force  $F_e$  becomes weaker than chemical force  $F_c$  and chemical force pulls negative ions from the positive plate (anode) and makes them move towards the negative plate (cathode). The negative terminal pushes one electron into the conductor because of stronger repulsion between negative terminal and negative ion.

Hence, the total number of electrons in the conductor remains constant during the current flow. The above said process continuous till equilibrium is attained

between the forces  $F_e$  and  $F_c$ .

#### 3. Write the difference between potential difference and emf.

**A.**

	Potential difference	Electro motive force
1	The amount of work done by electric force to move unit positive charge in between two points.	The amount of work done by chemical force to move unit positive charge from anode to cathode.
2	This can be measured between any two points in the conductor.	This can be measured for the batteries.
3	This depends upon the flow of current and resistance of the conductor.	This does not depends upon the flow of current and resistance of the conductor.
4	Always less than the value of e.m.f.	Always greater than the value of potential difference.

#### 4. How can you verify that the resistance of a conductor is temperature dependent?

**A.** Measure the resistance of the bulb with multi meter.

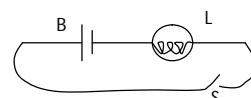

Connect a circuit with components battery, wires and bulb. Switch on the circuit. After few minutes, measure the resistance of the bulb again. The value of resistance of the bulb in In circuit is more than the resistance of the bulb when it is not in circuit.

We observed that the bulb gets heated. The increase in temperature of the filament in the bulb is responsible for increase in resistance of the bulb. Hence we can conclude that there is a relation between resistance of the bulb and its temperature. Thus the value of resistance of a conductor depends on temperature for constant potential difference between the ends of the conductor.

## 5. What do you mean by electric shock?

**Explain how it takes place..**

- A. The current passing through our body when we touch a live wire of 240V is given by  $I = 240/100000 = 0.0024A$ . When this quantify of current flows through the body, the functioning of organs inside the body gets disturbed. This disturbance inside the body is felt as electric shock.

If the current flow continues further, it damages the tissues of the body which leads to decrease in resistance of the body. Sometimes it may cause to death also.

## 6. Derive $R = \frac{\rho l}{A}$

- A. At constant temperature, the resistance of a conductor is directly proportional to the length of the conductor.

$$R \propto l$$

At constant temperature, the resistance of a conductor is inversely proportional to the area of cross section of the conductor.

$$R \propto \frac{1}{A}$$

Finally  $R \propto \frac{l}{A} \rightarrow R = \frac{\rho l}{A}$

Here,  $\rho$  is called as specific resistance or resistivity.

## 7. How do you verify that resistance of a conductor is proportional to the length of the conductor for constant cross section area and temperature?

A.

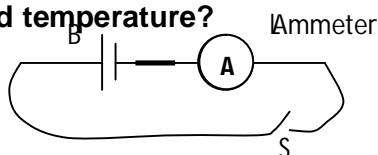

Collect iron spokes of different lengths with the same area of cross section. Make a circuit with battery, Ammeter, iron spoke and switch. Connect one of the iron spokes, say 10cm length in the circuit. Switch on to allow the flow of current. Measure the value of the current using the ammeter. Repeat this for other lengths of the iron spokes.

The current decreases with increase in the length of the spoke. Thus the resistance of each spoke increases with increase in the length for a constant potential difference.

NAGA MURTHY- 9441786635  
Contact at : [nagamurthsir@gmail.com](mailto:nagamurthsir@gmail.com)  
Visit at : [ignitephysics.weebly.com](http://ignitephysics.weebly.com)

We can conclude that the resistance (R) of a conductor is directly proportional to its length (l) for a constant potential difference. i.e.  $R \propto l$  (at constant temperature and area of cross section)

## 8. Explain Kirchhoff's laws with examples.

- A. **Kirchhoff's laws** : Two simple rules called Kirchhoff's rules are applicable to any DC circuit containing batteries and resistors connected in any way.

**Junction Law** : At any junction point in a circuit where the current can divide, the sum of the currents into the junction must equal the sum of the currents leaving the junction. This means that there is no accumulation of electric charges at any junction in a circuit. This law is based on the conservation of charge.

As per Junction law,

$$I_1 + I_2 + I_4 = I_3 + I_5$$

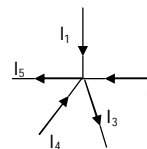

**Loop Law** : The algebraic sum of the increases and decreases in potential difference across various components of the circuit in a closed circuit loop must be zero. This law is based on the conservation of energy.

Thus, the algebraic sum of changes in potential differences is equal to zero.

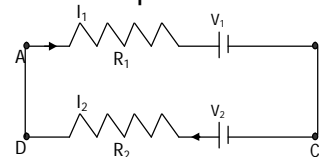

$$V_{AA} = 0$$

$$- I_1 R_1 - V_1 + V_2 - I_2 R_2 = 0$$

## 9. What is the value of 1 KWH in joules?.

- A. 1 KWH =  $3.6 \times 10^6$  Joules.

## 10. Explain over loading of household circuit.

- A. In the view of domestic power supplies, Potential difference: 240 V Current: 5 – 20A The maximum current that we can draw from the mains is 20A. When the current drawn from the mains exceeds the max limit 20A, then Overheating occurs and may cause a fire. This is called over loading.

**11. Why do we use fuses in house hold circuits?**

**A.** To prevent damages due to overload, we connect an electric fuse to the household circuit. The total current of the supply must pass through the fuse. In general, fuse is a thin wire of low melting point. When overload occurs, the fuse will melt due to heat. Then the circuit opens. The flow of current stopped. So there will be no damage in the house.

**12. Deduce an expression for the equivalent resistance of three resistors connected in series.**

**A. Series combination of resistors :** Consider three resistors  $R_1$ ,  $R_2$  and  $R_3$  are connected in series.  $V_1$ ,  $V_2$  and  $V_3$  are the potential differences between the ends of the resistors  $R_1$ ,  $R_2$  and  $R_3$  respectively. Let 'I' is the flow of current through them in the circuit.

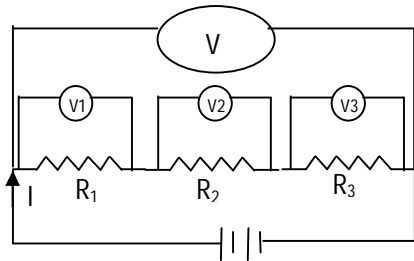

Ohm's law :  $V = I R$

Apply this ohm's law for  $R_1$ ,  $R_2$  and  $R_3$ .

Then  $V_1 = I R_1$   
 $V_2 = I R_2$   
 $V_3 = I R_3$

Let the resultant potential difference and R is the resultant resistance.

Then  $V = I R$

In series arrangement  $V = V_1 + V_2 + V_3$   
 $I R = I R_1 + I R_2 + I R_3$   
 $I R = I (R_1 + R_2 + R_3)$   
 $R = R_1 + R_2 + R_3$

If resistors connected in series combination then the resultant resistance is equal to the sum of the individual resistances of resistors.

**13. Deduce the expression for the equivalent resistance of three resistors connected in parallel.**

**A. Parallel combination of resistors :**

Consider three resistors  $R_1$ ,  $R_2$  and  $R_3$  are connected in parallel.  $I_1$ ,  $I_2$  and  $I_3$  are the flow of current through the resistors  $R_1$ ,  $R_2$  and  $R_3$  respectively. Let 'V' is the potential difference between the ends of each resistor.

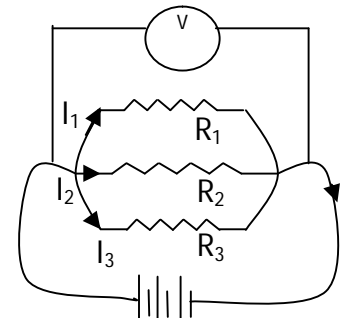

Ohm's law :  $V = I R \Rightarrow I = \frac{V}{R}$

Apply this ohm's law for  $R_1$ ,  $R_2$  and  $R_3$ .

Then  $I_1 = \frac{V}{R_1}$   
 $I_2 = \frac{V}{R_2}$   
 $I_3 = \frac{V}{R_3}$

Let the resultant flow of current is 'I' and R is the resultant resistance.

Then  $I = \frac{V}{R}$

In parallel arrangement  $I = I_1 + I_2 + I_3$

$$\frac{V}{R} = \frac{V}{R_1} + \frac{V}{R_2} + \frac{V}{R_3}$$

$$\frac{V}{R} = V \left( \frac{1}{R_1} + \frac{1}{R_2} + \frac{1}{R_3} \right)$$

$$\frac{1}{R} = \frac{1}{R_1} + \frac{1}{R_2} + \frac{1}{R_3}$$

If resistors connected in parallel combination then the reciprocal of the resultant resistance is equal to the sum of the reciprocals of the individual resistances of resistors.

**14. Silver is better conductor of electricity than copper. Why do we use copper wire for conduction of electricity?**

**A.** Silver is better conductor than copper. But economically copper is available at low cost. So we use copper wire for conduction of electricity.

NAGA MURTHY- 9441786635  
 Contact at : [nagamurthysir@gmail.com](mailto:nagamurthysir@gmail.com)  
 Visit at : [ignitephysics.weebly.com](http://ignitephysics.weebly.com)

ignitephysics.weebly.com

**15. Two bulbs have ratings 100W, 220V and 60W, 220V. Which one has the greater resistance?**

A. Power of electricity :  $P = \frac{V^2}{R} \rightarrow R = \frac{V^2}{P}$

Case(i) For first bulb  $P = 100 \text{ W}$ ,  
 $V = 220 \text{ V}$

$$R = \frac{V^2}{P} = \frac{220 \times 220}{100} = 484 \Omega$$

Case(ii) For second bulb  $P = 60 \text{ W}$   
 $V = 220 \text{ V}$

$$R = \frac{V^2}{P} = \frac{220 \times 220}{60} = 806.66 \Omega$$

Second bulb has greater resistance.

**16. Why don't we use series arrangement of electrical appliances like bulb, Television, fan and others in domestic circuits?**

A. In a series arrangement, if one bulb fails then the flow of electricity will be stopped in that circuit. It means that if a TV is failed, then all other appliances like fan, bulb and other devices stopped as the circuit is opened. So we don't use series arrangement for household appliances.

**17. A wire of length 1m and radius 0.1mm has a resistance of 100Ω. Find the resistivity of the material.**

A. The length of resistance ( $l$ ) = 1 m  
Radius of the wire ( $r$ ) = 0.1 mm  
 $= 0.1 \times 10^{-3} \text{ m}$   
 $= 1 \times 10^{-4} \text{ m}$

Area of cross section of wire ( $A$ ) =  $\pi r^2$   
 $= \frac{22}{7} \times (1 \times 10^{-4})^2$   
 $= \frac{22}{7} \times 10^{-8}$

Resistance ( $R$ ) = 100 Ω

Resistivity ( $\rho$ ) =  $\frac{RA}{l}$   
 $= \frac{100 \times (\frac{22}{7} \times 10^{-8})}{1}$   
 $= 3.14 \times 10^{-6} \Omega\text{-m}$

**18. Why do we consider tungsten as a suitable material for making the filament**

A. Tungsten has high resistance and high melting point. It can not melt even the temperature is more than 1650°C. While current is passing through a wire, it becomes hot and emits light. So Tungsten is the suitable material for making filaments of a bulb.

**19. Are the head lights of a car connected in series or parallel? Why?**

A. In a series arrangement, if one bulb fails then the flow of electricity will be stopped in that circuit. It means that if a bulb is failed, then all other bulbs will stop as the circuit is opened. So we don't use series arrangement for head lights of a car. They should be connected in parallel.

**20. Why should we connect electric appliances in parallel in a household circuit? What happened if they are connected in series?**

A. In a parallel arrangement, if one bulb fails then the flow of electricity will not be stopped in that circuit. It means that if a TV is failed, then all other appliances like fan, bulb and other devices works as usual as the circuit is closed. So we use parallel arrangement for household appliances.

In a series arrangement, if one bulb fails then the flow of electricity will be stopped in that circuit. It means that if a TV is failed, then all other appliances like fan, bulb and other devices stopped as the circuit is opened. Also devices get less voltage in series arrangement as the potential difference is divided in the circuit.

**21. Suppose that you have three resistors each of 30Ω. How many resistors can you obtain by various combinations of these three resistors? Draw the diagrams in support of your predictions.**

A. Three different resistors may connected in different ways to get different resistance values.

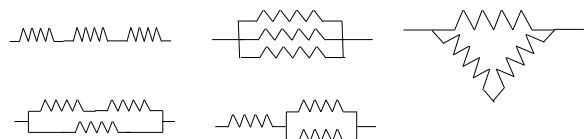

**22. State Ohm's law. Suggest an experiment to verify it and explain the procedure.**

**A. Ohm's law:** The potential difference between the ends of a conductor in a circuit is directly proportional to the flow of current in the circuit.  $V \propto I$  (or)  $\frac{V}{I} = \text{constant}$

**Experiment:** Connect a closed circuit with the devices battery with one cell, plug key, iron spoke (for resistance), and ammeter in series combination. Attach volt meter at the ends of the resistor in parallel combination. Now switch on and allow the flow of current in the circuit. Take the readings of ammeter as flow of current 'I' and the reading in the volt meter as 'V'. Find  $\frac{V}{I}$ .

Note down the values in the table.

S.No	Potential difference (V)	Flow of current (I)	$\frac{V}{I}$
1			
2			

Repeat the same with battery having 2 or 3 cells. In each case find the value of  $\frac{V}{I}$ .

We get  $\frac{V}{I}$ , a constant value. So  $\frac{V}{I} = \text{constant}$

$$V \propto I$$

Hence Ohm's law is verified.

**24. Draw a circuit diagram for a circuit in which two resistors A and B are connected in series with a battery and a voltmeter is connected to measure the potential difference across the resistor A.**

**A.**

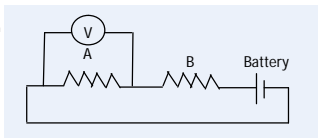

**25. How can you appreciate the role of a small fuse in house wiring circuit in preventing damage to various electric appliances connected in the circuit?**

**A.** The total current of the supply must pass through the fuse. In general, fuse is a thin wire of low melting point. When overload occurs, the fuse will melt due to heat. Then the circuit opens. The flow of current stopped. So there will be no damage in the house. So fuse plays a necessary and important role in household wiring process.

**26. In the given figure, the potential at A is ..... When the potential at B is zero.**

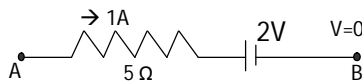

**A.** Potential difference is divided between A & B

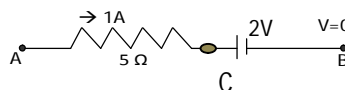

$$V_{BA} = V_{BC} + V_{CA}$$

$$V_A - V_B = +2 + (1 \times 5)$$

$$V_A - 0 = 2 + 5$$

$$V_A = 7 \text{ V}$$

**27. Observe the circuit and answer the questions given below.**

- Are resistors 3 and 4 in series?
- Are resistors 1 and 2 in series?
- Is the battery in series with any resistor?
- What is the potential drop across the resistor 3?
- What is the total emf in the circuit if the potential drop across resistor 1 is 6V?

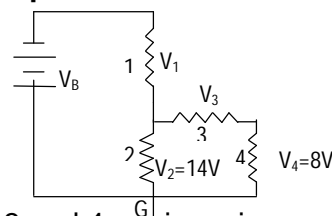

- A.**
- Resistors 3 and 4 are in series.
  - Resistors 1 and 2 are in series.
  - 
  - As resistor 2 connected parallel to 3 and 4  
 $V_2 = V_3 + V_4 \rightarrow 14 = V_3 + 8 \rightarrow V_3 = 6 \text{ V}$
  - Given  $V_1 = 6 \text{ V}$   
 As battery connected in series to 1 and 2  
 $V_B = V_1 + V_2 = 6 + 14 = 20 \text{ V}$

**28. If the resistance of your body is 100000Ω, what would be the current that flows in your body when you touch the terminals of a 12V battery?**

**A.**

$$\text{Resistance (R)} = 100000 \Omega$$

$$\text{Potential of the battery (V)} = 12 \text{ V}$$

$$\text{Ohm's law : } V = IR$$

$$I = \frac{V}{R} = \frac{12}{100000} = 12 \times 10^{-5} \text{ A}$$

The flow of current through the body is  $12 \times 10^{-5}$  Ampere

NAGA MURTHY- 9441786635  
 Contact at : [nagamurthysir@gmail.com](mailto:nagamurthysir@gmail.com)  
 Visit at : [ignitphysics.weebly.com](http://ignitphysics.weebly.com)

29. A uniform wire of resistance  $100\Omega$  is melted and recast into wire of length double that of the original. What would be the resistance of the new wire formed?

A. A wire is melted and reshaped.

At first: Resistance ( $R_1$ ) =  $100\ \Omega$

Length of wire ( $l_1$ ) =  $l$

Area of cross section ( $A_1$ ) =  $A$

As the wire is in cylindrical shape

The volume =  $A \times l$

At final: Resistance ( $R_2$ ) =  $R\ \Omega$

Length of wire ( $l_2$ ) =  $2l$

Area of cross section ( $A_2$ ) =  $\frac{A}{2}$

Resistivity ( $\rho = \frac{RA}{l}$ ) of a metal does not change as per measurements.

$$\frac{R_1 A_1}{l_1} = \frac{R_2 A_2}{l_2}$$

$$\frac{100 \times A}{l} = \frac{R \times \frac{A}{2}}{2l}$$

$$100 = \frac{R}{4}$$

$$R = 400\ \Omega$$

30. A house has 3 tube lights, two fans and a television. Each tube light draws 40W. The fan draws 80W and the television draws 60W. On the average, all the tube lights are kept on for five hours, two fans for 12 hours and television for five hours every day. Find the cost of electric energy used in 30 days at the rate of Rs. 3.00 per KWH.

A. Energy consumed in a day =

$$\frac{\text{Wattage} \times \text{Number of devices} \times \text{usage hours per day}}{1000}$$

Device	Wattage	Number of devices	Usage hours per day	Consumed energy in KWH
Tube light	40	3	5	$\frac{40 \times 3 \times 5}{1000} = 0.6$
Fan	80	2	12	$\frac{80 \times 2 \times 12}{1000} = 1.92$
TV	60	1	5	$\frac{60 \times 1 \times 5}{1000} = 0.3$

$$\text{Energy consumed in a day} = 0.6 + 1.92 + 0.3 = 2.82\ \text{KWH}$$

$$\text{Energy consumed in 30 days} = 30 \times 2.82 = 84.6\ \text{KWH}$$

$$\text{Rate of current for 1 KWH} = \text{Rs. } 3-00$$

$$\begin{aligned} \text{Total cost (Current bill)} &= 84.6 \times 3-00 \\ &= \text{Rs. } 253-80 \end{aligned}$$

NAGA MURTHY- 9441786635

Contact at : [nagamurthysir@gmail.com](mailto:nagamurthysir@gmail.com)

Visit at : [ignitephysics.weebly.com](http://ignitephysics.weebly.com)